



Rewarding Learning

ADVANCED  
General Certificate of Education  
2024

Centre Number

--	--	--	--	--

Candidate Number

--	--	--	--

## Physics

Assessment Unit A2 3B

*assessing*

Practical Techniques  
and Data Analysis

**MV18**

**[APH32]**

**MONDAY 17 JUNE, MORNING**

### Time

1 hour, plus your additional time allowance.

### Instructions to Candidates

Write your Centre Number and Candidate Number in the spaces provided at the top of this page.

**You must answer the questions in the spaces provided.**

**Do not write on blank pages.**

Complete questions in black ink and use a dark HB pencil for drawings and graphs.

Answer **all five** questions.

### Information for Candidates

The total mark for this paper is 50.

Figures in brackets printed at the end of each question indicate the marks awarded to each question or part question.

You may use a scientific calculator.

An A3 insert has been provided for use with Question **3(c)(ii)**.

At the end of the examination, attach this insert to your Question Paper using the treasury tag provided.

- 1 A cathode ray oscilloscope is being used to display audible sound waves produced by a vibrating tuning fork. The audible frequency range of sound waves is 20–20,000 Hz. The pattern of waves observed on the screen is shown in **Fig. 1.1**.

**Fig. 1.1**

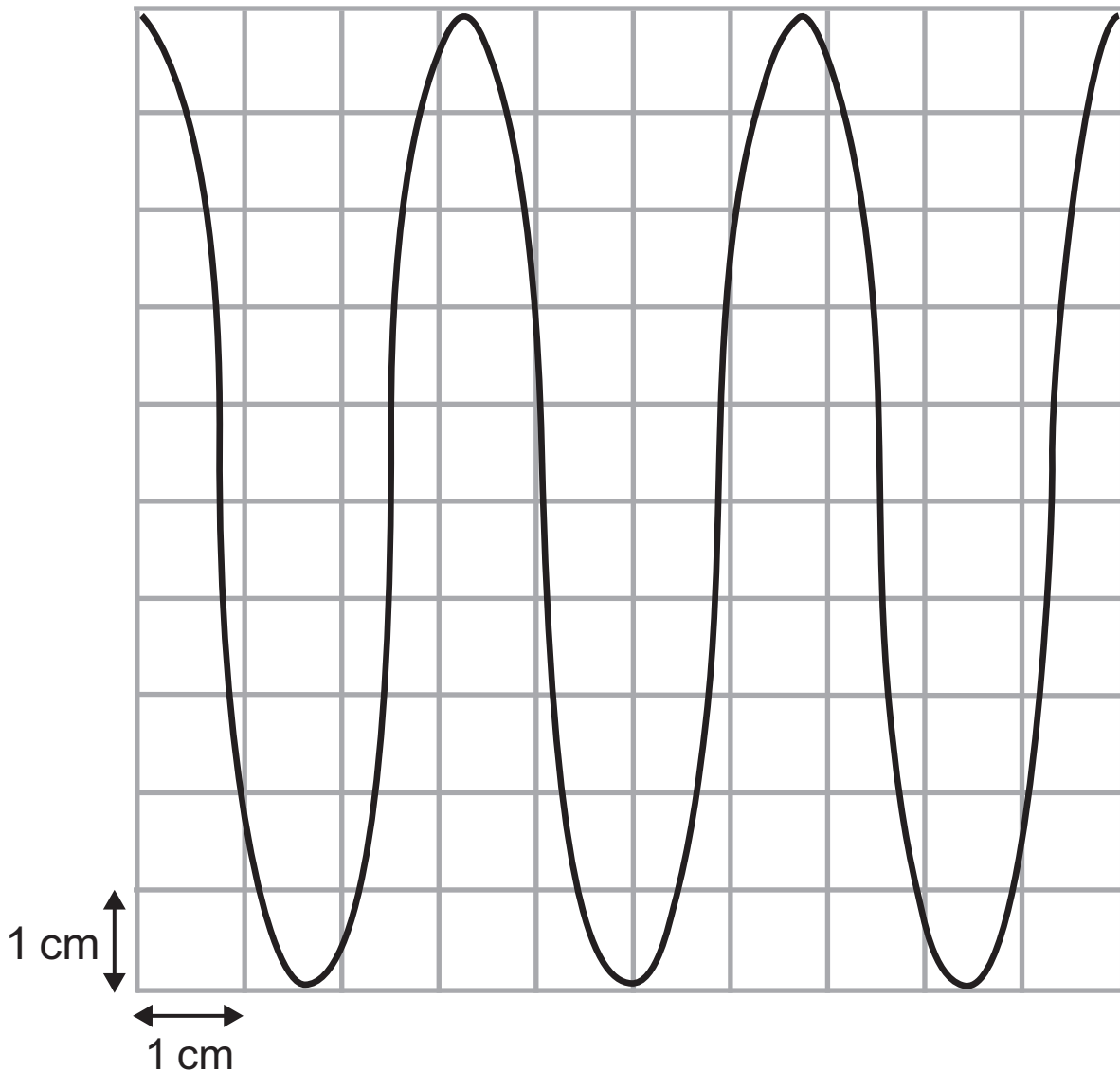

**diagram not to scale**

The students using the oscilloscope cannot read the timebase setting, due to the display digits being worn away. They cannot tell whether the setting is  $50 \text{ ms cm}^{-1}$  or  $500 \mu\text{s cm}^{-1}$ . Carry out calculations to determine which of the two values is the correct one for the audible sound wave, and give a reason for your answer. [6 marks]

Timebase setting = \_\_\_\_\_

Reason for choosing this setting:

---

---

---

2 A  $100\text{ cm}^3$  laboratory beaker is shown in **Fig. 2.1**.

**Fig. 2.1**

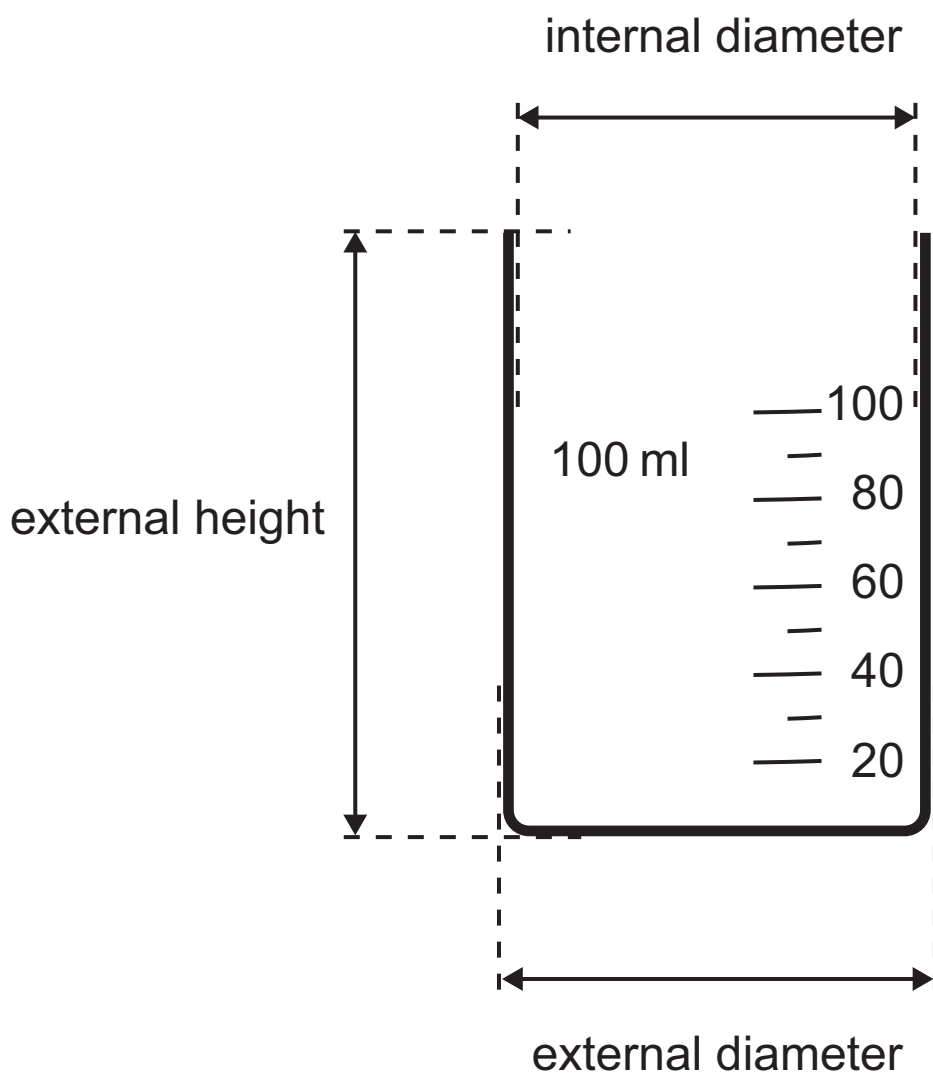

Various measurements of the beaker were made and recorded in **Table 2.1**.

**Table 2.1**

Measurement	Value / cm
External height	6.80
Internal diameter	4.76
External diameter	5.04

**(a)** What instrument was used to take these measurements? [1 mark]

---

(b) The volume of a cylinder of diameter  $d$  and height  $h$  is given by **Equation 2.1**.

**Equation 2.1**

$$\text{Volume} = \frac{\pi d^2 h}{4}$$

Use the values given in **Table 2.1** and **Equation 2.1** to calculate:

(i) the external volume of the beaker. [3 marks]

External volume = \_\_\_\_\_  $\text{cm}^3$

**(ii)** the percentage uncertainty in the value you have calculated in **(i)**. [3 marks]

Percentage uncertainty = \_\_\_\_\_ %

**(iii)** the thickness of the glass wall of the beaker.  
[1 mark]

Thickness = \_\_\_\_\_ cm

(iv) the volume of glass used to make the beaker, assuming the thickness of the wall is the same as the thickness of the base of the beaker. [3 marks]

Volume of glass used = \_\_\_\_\_ cm<sup>3</sup>

**Blank Page**  
**(Questions continue overleaf)**

- 3 A very flexible plastic rod was clamped over the edge of a desk. The length of the rod overhanging the desk was varied and values of distances A and B, as shown in Fig. 3.1, were measured.

Fig. 3.1

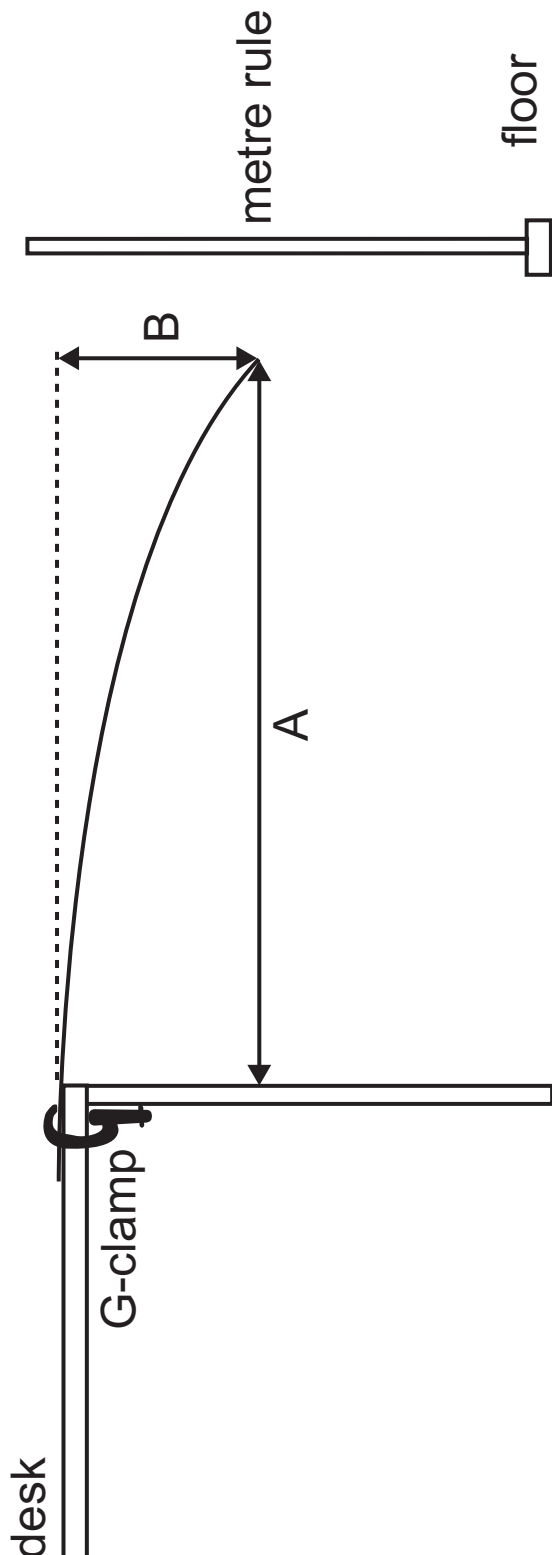

- (a) The distance B was measured using a metre rule placed on the floor as shown in **Fig. 3.1**. Suggest how the measurement can be made as accurate as possible.  
[2 marks]
- 
- 

- (b) The relationship between A and B is given by **Equation 3.1**, where n is an integer.

**Equation 3.1**

$$B = k A^n$$

By mapping to the equation of a straight line, show that a graph of  $\log_{10} B$  against  $\log_{10} A$  will be a straight line with a gradient equal to the integer n. [2 marks]

(c) Values of A and B are shown in **Table 3.1**.

**Table 3.1**

<b>A / cm</b>	<b>B / cm</b>		
106.6	38.5		
94.9	21.4		
84.3	15.0		
73.8	8.8		
63.0	4.5		

- (i) Calculate the values of the additional quantities required in order to draw the graph and record these to 2 decimal places in **Table 3.1**. Head the columns appropriately. [4 marks]
- (ii) Select suitable scales and label the axes to enable you to plot a graph of  $\log B$  against  $\log A$  on the grid of **Fig. 3.2** (on the A3 insert provided). Draw the best fit straight line for the points plotted. [5 marks]

**(d) (i)** Use your graph to determine a value for the integer  $n$ . [3 marks]

$n =$  \_\_\_\_\_

- (ii) Use your value of  $n$  to find a value for the constant  $k$  and determine the unit of the constant  $k$ .  
[5 marks]

$k =$  \_\_\_\_\_

Unit of  $k =$  \_\_\_\_\_

- 4 Electric current is passed through metal wires of the same material and length but different diameters. The current is increased until the wire melts and the circuit is broken. The value of the current is recorded and the process repeated for each wire of different diameter. The 'fusing current' is the name given to the current value at which the piece of wire melts.

**Table 4.1** shows the fusing currents for the wires of different diameter.

**Table 4.1**

Diameter $d$ / mm	Fusing current $I_f$ / A
1.02	84.0
0.81	58.6
0.57	36.7
0.40	20.5
0.21	7.3

Preece's law states that the fusing current  $I_f$  depends upon the diameter  $d$  of the wire as shown by **Equation 4.1**

**Equation 4.1**

$$I_f = C d^{3/2}$$

where  $C$  is a constant called Preece's coefficient.

- (a) The graph of **Fig. 4.1** opposite indicates a proportional relationship between the two quantities that have been plotted. Given that  $I_f^2$  has been plotted on the y-axis, use **Equation 4.1** and **Fig 4.1** to determine the quantity plotted on the x-axis and its unit. [2 marks]

Quantity on x-axis = \_\_\_\_\_

Unit = \_\_\_\_\_

- (b) Draw the line of best fit on **Fig 4.1**. [1 mark]

Fig. 4.1

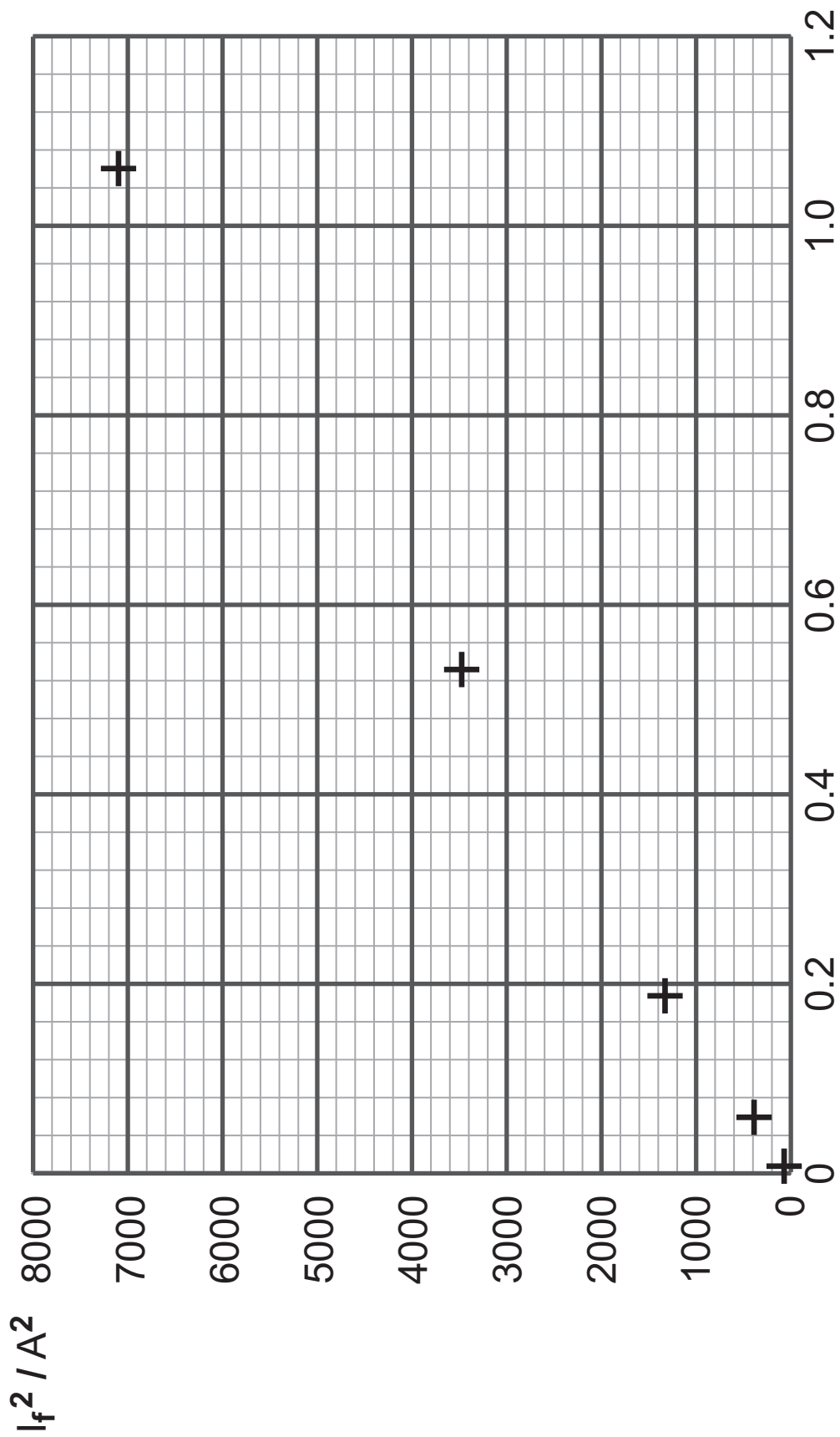

- (c) Determine the fusing current that would be expected for a wire of the same material with a diameter of 0.90 mm.  
[3 marks]

Fusing current = \_\_\_\_\_ A

- 5 In an experiment to investigate the pressure law, a fixed volume of gas was heated in a flask in a water bath as shown in **Fig. 5.1**.

The gas pressure was measured using a pressure gauge and the temperature using a thermometer.

**Fig. 5.1**

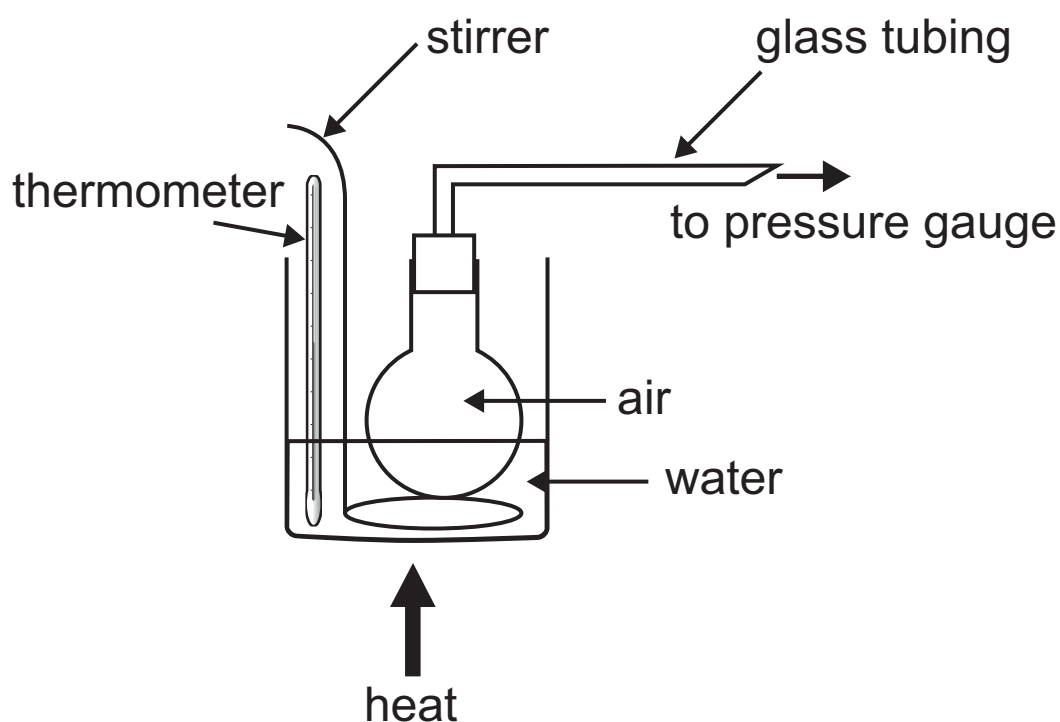

- (a) In order to obtain more accurate results, suggest how the apparatus as shown in **Fig. 5.1** should be modified and why this should be done. [2 marks]

---

---

---

---

**(b)** Why is it good practice to stir the water as it is heated?  
[1 mark]

---

---

**(c)** The pressure law states that for a constant volume of gas the absolute temperature and pressure are directly proportional. A straight line graph through the origin as shown in **Fig. 5.2** opposite would confirm proportionality.

**(i)** Add labels, including quantity and unit, to the axes on **Fig. 5.2**. [2 marks]

**(ii)** On **Fig. 5.2**, indicate, on the line, the location of the range within which the raw data obtained using the apparatus shown in **Fig. 5.1** would be plotted.  
[1 mark]

**Fig. 5.2**

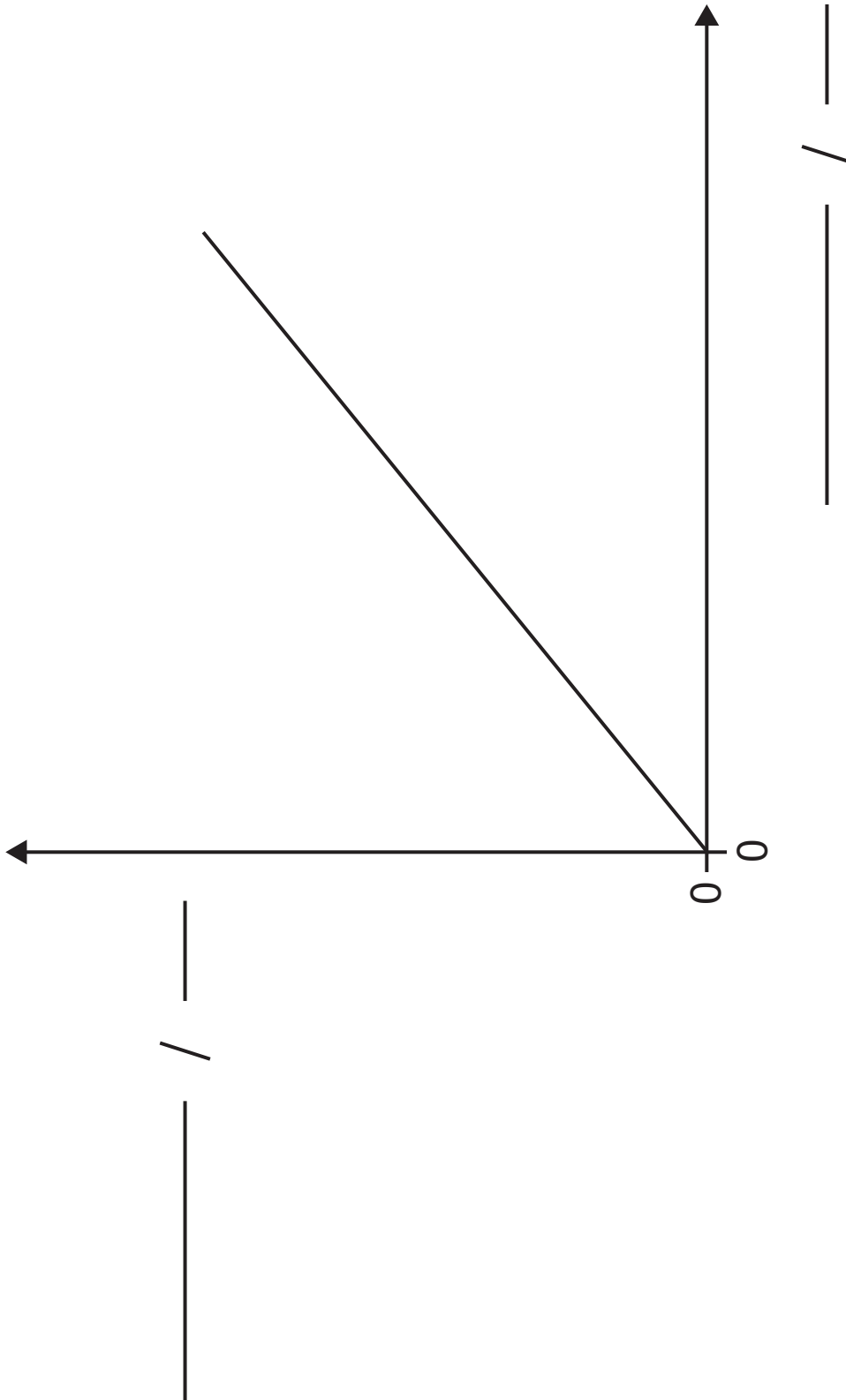

---

**This is the end of the question paper**

---



For Examiner's use only	
Question Number	Marks
1	
2	
3	
4	
5	
<b>Total Marks</b>	

Examiner Number

Permission to reproduce all copyright material has been applied for. In some cases, efforts to contact copyright holders may have been unsuccessful and CCEA will be happy to rectify any omissions of acknowledgement in future if notified.

Insert for use with Question 3(c)(ii).

At the end of the examination, attach this insert to your Question Paper using the treasury tag provided.

Centre Number

--	--	--	--	--

Candidate Number

--	--	--	--

